

# ZCT26N12

limit switch body ZCT - compact - 1NC+1NO -  
slow-break - 1/2"NPT

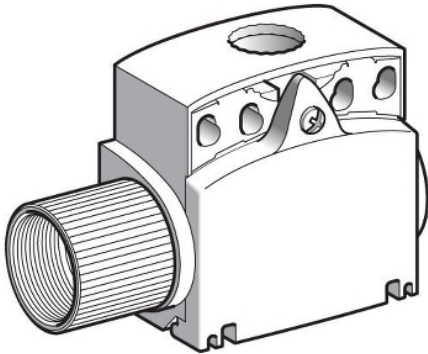

## Main

Range of product	Telemecanique Limit switches XC Standard
Series name	Standard compact
Product or component type	Limit switch body
Device short name	ZCT
Design	Compact
Body type	Fixed
Associated head	ZCE08 ZCE07 ZCE24 ZCE21 ZCE66 ZCE14 ZCE64 ZCE11 ZCE65 ZCE28 ZCE27 ZCE13 ZCE02 ZCE63 ZCE05 ZCE01 ZCE29 ZCE06 ZCEH2 ZCE62 ZCE10 ZCEH0 ZCE67
Body material	Plastic
Number of poles	2
Contacts type and composition	1 NC + 1 NO
Contact operation	Slow-break, make before break

## Complementary

Electrical connection	Screw-clamp terminals, clamping capacity: 1 x 0.5...2 x 2.5 mm <sup>2</sup>
Cable entry	2 entries tapped for 1/2" NPT adaptor, cable outer diameter: 4...8 mm
Contacts insulation form	Zb
Contacts material	Silver plated contacts
Positive opening	With
Minimum actuation speed	6 m/s
Contact code designation	B300, AC-15 (U <sub>e</sub> = 240 V), I <sub>e</sub> = 1.5 A conforming to EN/IEC 60947-5-1 appendix A R300, DC-13 (U <sub>e</sub> = 250 V), I <sub>e</sub> = 0.1 A conforming to EN/IEC 60947-5-1 appendix A
[Ui] rated insulation voltage	300 V conforming to UL 508 500 V (pollution degree 3) conforming to IEC 60947-1 300 V conforming to CSA C22.2 No 14
[Uimp] rated impulse withstand voltage	6 KV conforming to IEC 60664 6 kV conforming to IEC 60947-1
Short-circuit protection	10 A cartridge fuse, type gG

The information provided in this documentation contains general descriptions and/or technical characteristics of the performance of the products contained herein. This documentation is not intended as a substitute for and is not to be used for determining suitability or reliability of these products for specific user applications. It is the duty of any such user or integrator to perform the appropriate and complete risk analysis, evaluation and testing of the products with respect to the relevant specific application or use thereof. Neither TWSS Holding nor any of its affiliates or subsidiaries shall be responsible or liable for misuse of the information contained herein.

Electrical durability	5000000 Cycles, DC-13 120 V, 7 W, operating rate <60 cyc/mn, load factor: 0.5 conforming to IEC 60947-5-1 appendix C 5000000 Cycles, DC-13 24 V, 13 W, operating rate <60 cyc/mn, load factor: 0.5 conforming to IEC 60947-5-1 appendix C 5000000 cycles, DC-13 48 V, 9 W, operating rate <60 cyc/mn, load factor: 0.5 conforming to IEC 60947-5-1 appendix C
Width	58 mm
Height	51 mm
Depth	30 mm
Net weight	0.085 kg

## Environment

Product compatibility	XCKT
Ambient air temperature for operation	-25...70 °C
Ambient air temperature for storage	-40...70 °C

## Packing Units

Unit Type of Package 1	PCE
Number of Units in Package 1	1

## Contractual warranty

Warranty	18 months
----------	-----------