

XU1N18PP341W

Photoelectric sensors XU, XU1, reflex, 90°, Sn
4 m, 12...24 VDC, cable 2 m

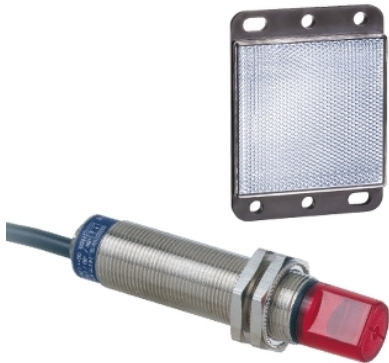

Main

Range of product	Telemecanique Photoelectric sensors XU
Series name	Application food and beverage
Electronic sensor type	Photo-electric sensor
Sensor name	XU1
Sensor design	Cylindrical M18
Detection system	Reflex
Material	Stainless steel
Line of sight type	90° lateral
Type of output signal	Discrete
Supply circuit type	DC
Wiring technique	3-wire
Discrete output type	PNP
Discrete output function	1 NO or 1 NC programmable
Electrical connection	Cable
Cable length	2 m
Product specific application	-
Emission	Infrared reflex
[Sn] nominal sensing distance	4 m reflex need reflector XUZC50

Complementary

Enclosure material	Stainless steel : 304 CU
Lens material	PMMA
Maximum sensing distance	5.5 m with reflector 50 x 50 mm
Output type	Solid state
Add on output	Without
Add on input	Programmation
Cable composition	4 x 0.34 mm ²
Wire insulation material	PvR
Cable outer diameter	4.2 mm
Status LED	1 LED (green) for supply on 1 LED (yellow) for output state
[Us] rated supply voltage	12...24 V DC with reverse polarity protection
Supply voltage limits	10...30 V DC
Switching capacity in mA	<= 100 mA (overload and short-circuit protection)
Switching frequency	<= 500 Hz
Maximum voltage drop	<1.5 V (closed state)
Current consumption	<= 30 mA no-load
Maximum delay first up	15 ms
Maximum delay response	1 ms
Maximum delay recovery	1 ms
Setting-up	Without sensitivity adjustment
Diameter	18 mm
Length	78 mm
Net weight	0.155 kg
Kit composition	Sensor Reflector XUZC50

The information provided in this documentation contains general descriptions and/or technical characteristics of the performance of the products contained herein. This documentation is not intended as a substitute for and is not to be used for determining suitability or reliability of these products for specific user applications. It is the duty of any such user or integrator to perform the appropriate and complete risk analysis, evaluation and testing of the products with respect to the relevant specific application or use thereof. Neither TWSS Holding nor any of its affiliates or subsidiaries shall be responsible or liable for misuse of the information contained herein.

Environment

Product certifications	CSA[RETURN]CE[RETURN]UL
Ambient air temperature for operation	-25...55 °C
Ambient air temperature for storage	-40...70 °C
Vibration resistance	25 gn, amplitude = +/- 1.5 mm (f = 10...55 Hz) conforming to IEC 60068-2-6
Shock resistance	30 gn (duration = 11 ms) conforming to IEC 60068-2-27
IP degree of protection	IP67 conforming to IEC 60529

Packing Units

Unit Type of Package 1	PCE
Number of Units in Package 1	1
Package 1 Height	4.5 cm
Package 1 Width	8.2 cm
Package 1 Length	13.3 cm
Package 1 Weight	166.0 g

Offer Sustainability

California proposition 65	WARNING: This product can expose you to chemicals including: Diisononyl phthalate (DINP), which is known to the State of California to cause cancer, and Di-isodecyl phthalate (DIDP), which is known to the State of California to cause birth defects or other reproductive harm. For more information go to www.P65Warnings.ca.gov
For all Reach Rohs enquiries contact us at	sustainability@tesensors.com

Contractual warranty

Warranty	18 months
----------	-----------

Dimensions

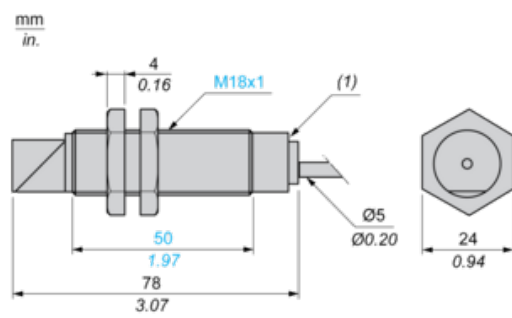

(1) LED

Mounting and Clearance

Fixing nut tightening torque: < 15 N.m

Connector tightening torque: 2 N.m

Wiring Schemes

3-wire, PNP NO or NC Programmable Function

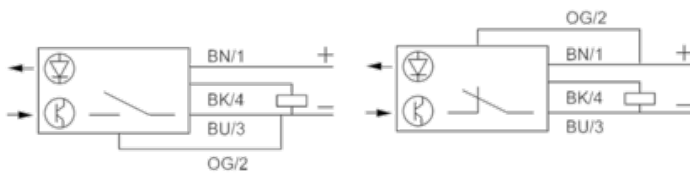

BN : Brown
BK : Black (out / output)
BU : Blue
OG : Orange (program)

Detection Curves

Reflex System with Reflector XUZC50

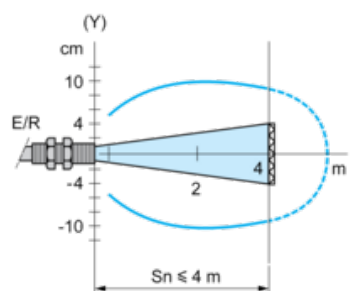

(y) Ø of beam

Excess Gain Curves (Ambient Temperature: + 25° C)

Reflex System with Reflector XUZC50

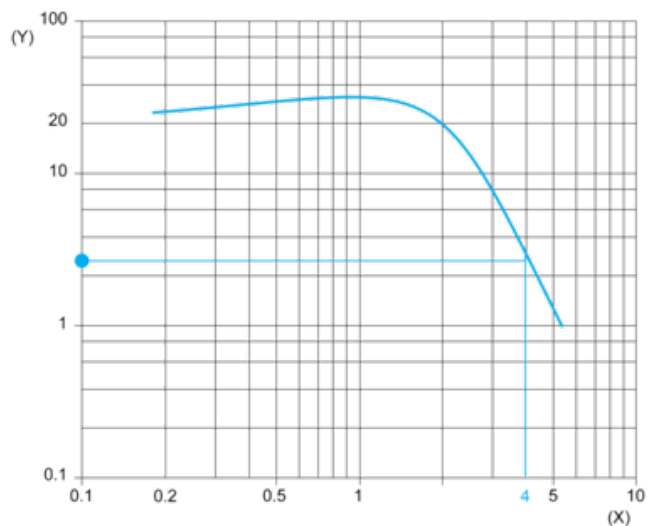

(y) Gain

(x) Distance (m)