

# XS8C40PC449H29

inductive sensor XS8 40x40x117 - plastic -  
Sn40mm - 12..48VDC - terminals



## Main

Range of product	Telemecanique Inductive proximity sensors XS
Series name	General purpose
Sensor type	Inductive proximity sensor
Device application	-
Sensor name	XS8
Sensor design	Form 40 x 40 x 117
Size	117 mm
Body type	Fixed
Detector flush mounting acceptance	Non flush mountable
Material	Plastic
Enclosure material	Plastic
Type of output signal	Discrete
Wiring technique	4-wire
[Sn] nominal sensing distance	40 mm
Discrete output function	1 NO or 1 NC programmable
Output circuit type	DC
Discrete output type	PNP
Electrical connection	Screw-clamp terminals, 4 x 1.5 mm <sup>2</sup>
[Us] rated supply voltage	12...48 V DC with reverse polarity protection
Switching capacity in mA	<= 200 mA with overload and short-circuit protection
IP degree of protection	IP67 conforming to IEC 60529

## Complementary

Detection face	5 positions turret head
Front material	Plastic
Operating zone	0...32 mm
Differential travel	3...20% of Sr
Repeat accuracy	<= 3% of Sr
Cable entry number	1 tapped entry for M20 x 1.5 cable gland
Status LED	Output state: 1 LED (yellow)
Supply voltage limits	10...58 V DC
Switching frequency	<= 500 Hz
Maximum voltage drop	<2 V (closed)
Current consumption	0...10 mA no-load
Maximum delay first up	5 ms
Maximum delay response	1 ms
Maximum delay recovery	1 ms
Marking	CE
Height	40 mm
Length	40 mm
Width	117 mm

The information provided in this documentation contains general descriptions and/or technical characteristics of the performance of the products contained herein. This documentation is not intended as a substitute for and is not to be used for determining suitability or reliability of these products for specific user applications. It is the duty of any such user or integrator to perform the appropriate and complete risk analysis, evaluation and testing of the products with respect to the relevant specific application or use thereof. Neither TWSS Holding nor any of its affiliates or subsidiaries shall be responsible or liable for misuse of the information contained herein.

## Environment

Product certifications	UL[RETURN]CSA[RETURN]CCC
Ambient air temperature for operation	-25...70 °C

## Packing Units

Unit Type of Package 1	PCE
Number of Units in Package 1	1

## Contractual warranty

Warranty	18 months
----------	-----------

Dimensions

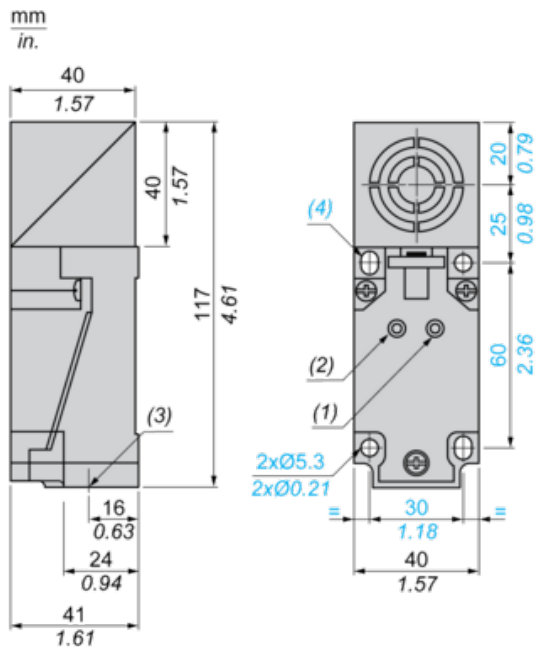

- (1) Output LED
- (2) Supply LED
- (3) 1 tapped entry for M20
- (4) 2 elongated holes  $\text{Ø} 5.3 \times 7$

---

Setting-up

---

Minimum Mounting Distances (mm)

Side by Side

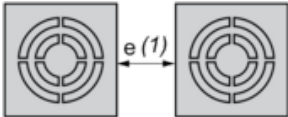

$$e (1) \geq 160$$

Face to Face

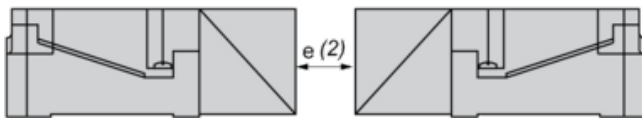

$$e (2) \geq 320$$

Facing a Metal Object

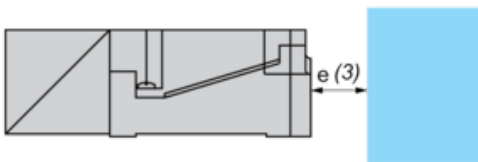

$$e (3) \geq 120$$

Tightening torque of cover fixing screws and clamp screws: < 1.2 N.m

---

## Wiring Schemes

---

### 4-Wire DC

