

XS7F1A1NAL01M8

Inductive proximity sensors XS, inductive sensor XS7 15x32x8, PBT, Sn5mm, 12...24 VDC, M8 0.15 m



Main

Range of product	Telemecanique Inductive proximity sensors XS
Series name	General purpose
Sensor type	Inductive proximity sensor
Device application	-
Sensor name	XS7
Sensor design	Flat form 15 x 32 x 8
Size	8 mm
Body type	Fixed
Detector flush mounting acceptance	Flush mountable
Material	Plastic
Enclosure material	PBT
Type of output signal	Discrete
Wiring technique	3-wire
Discrete output function	1 NO
Output circuit type	DC
Discrete output type	NPN
Electrical connection	Remote male connector M8, 3 pins
Cable length	0.15 m
[Us] rated supply voltage	12...24 V DC with reverse polarity protection
Switching capacity in mA	<= 100 mA DC with overload and short-circuit protection
IP degree of protection	IP68 conforming to IEC 60529

Complementary

Detection face	Frontal
Front material	PBT
Operating zone	0...4 mm
Differential travel	1...15% of Sr
Wire insulation material	PVC
Status LED	Output state: 1 LED (yellow)
Supply voltage limits	10...36 V DC
Switching frequency	<= 2000 Hz
Maximum voltage drop	<2 V (closed)
Current consumption	<= 10 mA no-load
Maximum delay first up	5 ms
Maximum delay response	0.1 ms
Maximum delay recovery	0.1 ms
Marking	CE
Depth	8 mm
Height	32 mm
Width	15 mm
Net weight	0.045 kg

Environment

Product certifications	CSA[RETURN]UL[RETURN]C-Tick
Ambient air temperature for operation	-25...70 °C
Ambient air temperature for storage	-40...85 °C
Vibration resistance	25 gn amplitude = +/- 2 mm (f = 10...55 Hz) conforming to IEC 60068-2-6
Shock resistance	50 gn for 11 ms conforming to IEC 60068-2-27

Packing Units

Unit Type of Package 1	PCE
Number of Units in Package 1	1
Package 1 Height	4.2 cm
Package 1 Width	9.5 cm
Package 1 Length	6.6 cm
Package 1 Weight	32.0 g
Unit Type of Package 2	S02
Number of Units in Package 2	22
Package 2 Height	15 cm
Package 2 Width	30 cm
Package 2 Length	40 cm
Package 2 Weight	1.164 kg
Unit Type of Package 3	P06
Number of Units in Package 3	352
Package 3 Height	105 cm
Package 3 Width	60 cm
Package 3 Length	80 cm
Package 3 Weight	19.764 kg

Offer Sustainability

Sustainable offer status	Green Premium product
Circularity Profile	No need of specific recycling operations
California proposition 65	WARNING: This product can expose you to chemicals including: Diisononyl phthalate (DINP), which is known to the State of California to cause cancer, and Di-isodecyl phthalate (DIDP), which is known to the State of California to cause birth defects or other reproductive harm. For more information go to www.P65Warnings.ca.gov
For all Reach Rohs enquiries contact us at	sustainability@tesensors.com

Contractual warranty

Warranty	18 months
----------	-----------

Dimensions

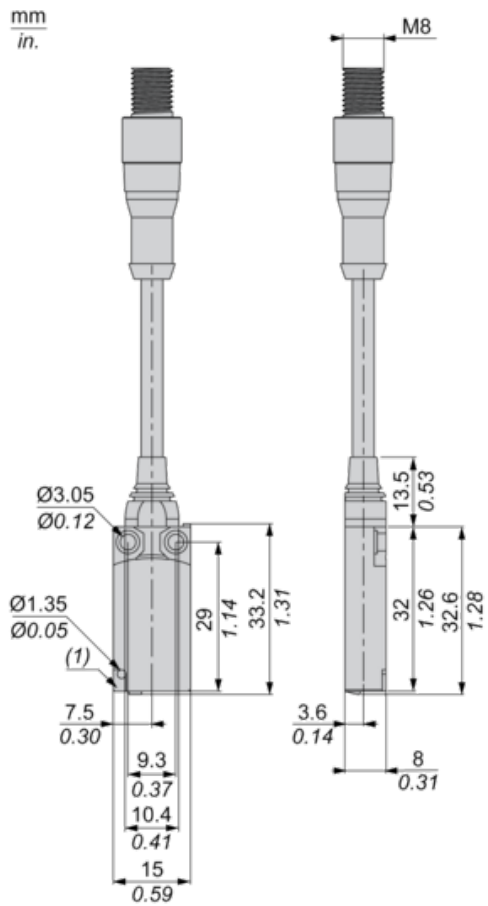

(1) LED

Setting-up

Minimum Mounting Distances (mm)

Side by Side

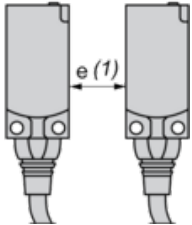

$$e (1) \geq 15$$

Face to Face

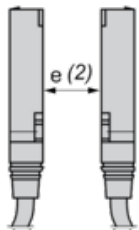

$$e (2) \geq 40$$

Facing a Metal Object

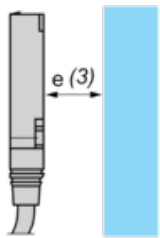

$$e (3) \geq 15$$

Wiring Schemes

NPN

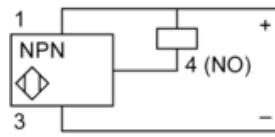

M8

