

XS7C40MP230TT

inductive sensor XS7 40x40x117 - plastic -
Sn15mm - 24..210VAC/DC - terminals



Main

Range of product	Telemecanique Inductive proximity sensors XS
Series name	General purpose
Sensor type	Inductive proximity sensor
Device application	-
Sensor name	XS7
Sensor design	Form 40 x 40 x 117
Size	117 mm
Body type	Fixed
Detector flush mounting acceptance	Flush mountable
Material	Plastic
Enclosure material	Plastic
Type of output signal	Discrete
Wiring technique	2-wire
[Sn] nominal sensing distance	15 mm
Discrete output function	1 NO or 1 NC programmable
Output circuit type	AC/DC
Electrical connection	Screw-clamp terminals, 2 x 1.5 mm ²
[Us] rated supply voltage	24...240 V AC 50/60 Hz 24...210 V DC
Switching capacity in mA	5...200 mA DC 5...300 mA AC
IP degree of protection	IP67 conforming to IEC 60529

Complementary

Detection face	5 positions turret head
Front material	Plastic
Operating zone	0...12 mm
Differential travel	3...20% of Sr
Repeat accuracy	<= 3% of Sr
Status LED	Output state: 1 LED (yellow)
Supply voltage limits	20...264 V AC/DC
Maximum residual current	0.8 mA open state 24 V 1.5 mA open state 120 V
Switching frequency	<= 25 Hz AC <= 50 Hz DC
Maximum voltage drop	<5.5 V (closed)
Maximum delay first up	120 ms
Maximum delay response	30 ms
Maximum delay recovery	20 ms
Marking	CE
Height	40 mm
Length	40 mm
Width	117 mm

Environment

Product certifications	UL[RETURN]CCC[RETURN]C-Tick[RETURN]CSA
Ambient air temperature for operation	-25...85 °C

Packing Units

Unit Type of Package 1	PCE
Number of Units in Package 1	1

Contractual warranty

Warranty	18 months
----------	-----------

Dimensions

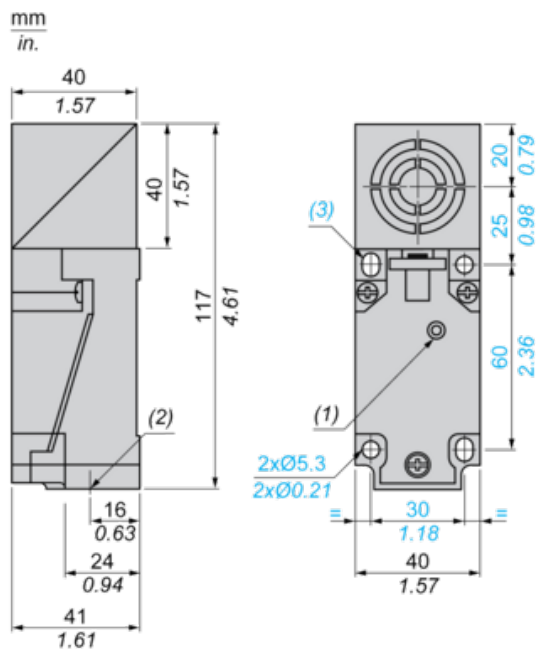

- (1) Output LED
- (2) 1 tapped entry for Pg 13.5 cable gland
- (3) 2 elongated holes Ø 5.3 x 7

Setting-up

Minimum Mounting Distances (mm)

Side by Side

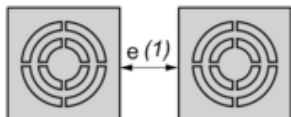

$$e(1) \geq 40$$

Face to Face



$$e(2) \geq 120$$

Facing a Metal Object



$$e(3) \geq 45$$

Wiring Schemes

2-Wire AC or DC Programmable, NO or NC Output Depending on Position of Link

