

XS1M30AB120L1

inductive sensor XS1 M30 - L50mm - brass - Sn10mm - 12..24VDC - cable 5m



Main

Range of product	Telemecanique Inductive proximity sensors XS
Series name	Application
Sensor type	Inductive proximity sensor
Electrical circuit type	Analog output
Sensor name	XS1
Sensor design	Cylindrical M30
Size	54 mm
Body type	Fixed
Detector flush mounting acceptance	Flush mountable
Material	Metal
Type of output signal	Analogue
Wiring technique	2-wire
[Sn] nominal sensing distance	10 mm
Discrete output function	1 NC
Output circuit type	DC
Analogue output range	4...20 mA
Electrical connection	Cable
Cable length	5 m
[Us] rated supply voltage	12...24 V DC
IP degree of protection	IP67 conforming to IEC 60529

Complementary

Thread type	M30 x 1.5
Detection face	Frontal
Front material	PPS
Enclosure material	Nickel plated brass
Operating zone	1...10 mm
Repeat accuracy	<= 3% of Sr
Linearity error	+/- 2 mA
Cable composition	3 x 0.34 mm ²
Wire insulation material	PVC
Supply voltage limits	10...36 V DC
Switching frequency	<= 300 Hz
Current consumption	4 mA no-load
Maximum output current drift	10 %
Marking	CE
Threaded length	42 mm
Height	30 mm
Length	50 mm

Environment

Product certifications	CSA[RETURN]UL
Ambient air temperature for operation	-25...70 °C

Packing Units

Unit Type of Package 1	PCE
Number of Units in Package 1	1

Contractual warranty

Warranty	18 months
----------	-----------

Dimensions

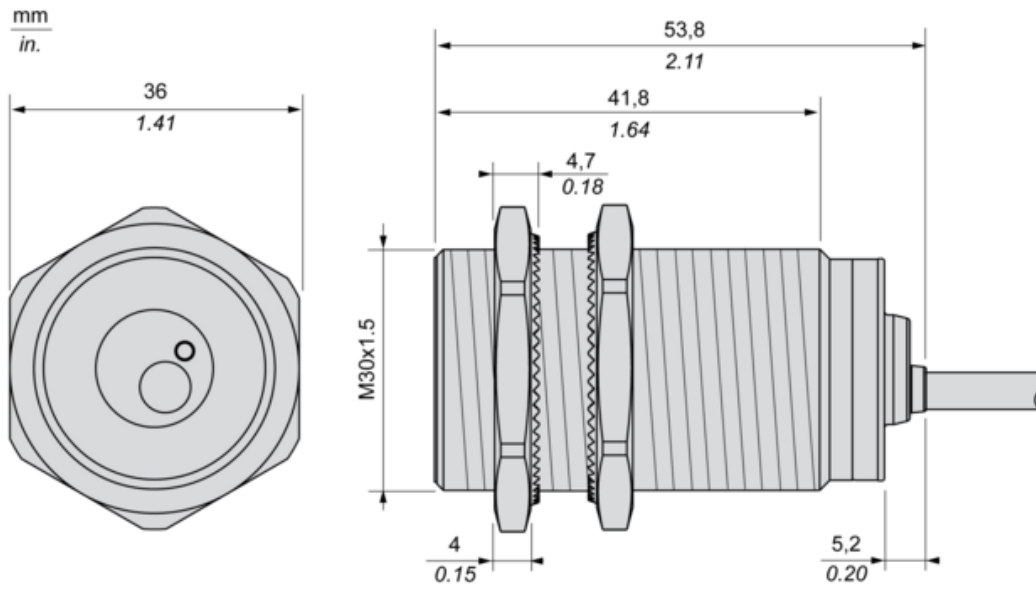

Minimum Mounting Distances

Side by side

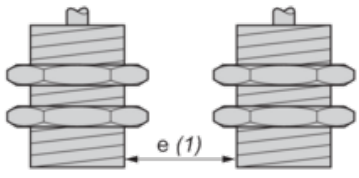

$e (1) \geq 20 \text{ mm}/0.79 \text{ in}$

Face to face

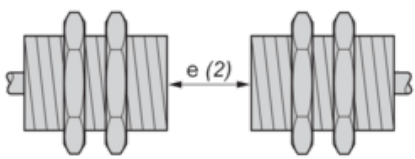

$e (2) \geq 120 \text{ mm}/4.72 \text{ in}$

Facing a metal object

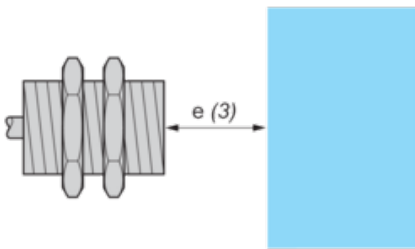

$e (3) \geq 30 \text{ mm}/1.18 \text{ in.}$

Wiring Schemes

2-Wire connection

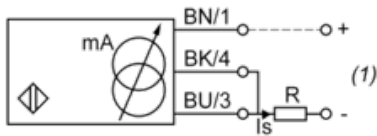

(1) Output current

BN : Brown

BK : Black

BU : Blue

	Output current	Load impedance value
12 V	4...20 mA	$R \leq 8.2 \Omega$
24 V	4...20 mA	$R \leq 470 \Omega$
Ensure a minimum of 10 V between the + and the - (terminal 3) of the sensor.		

Output Curves

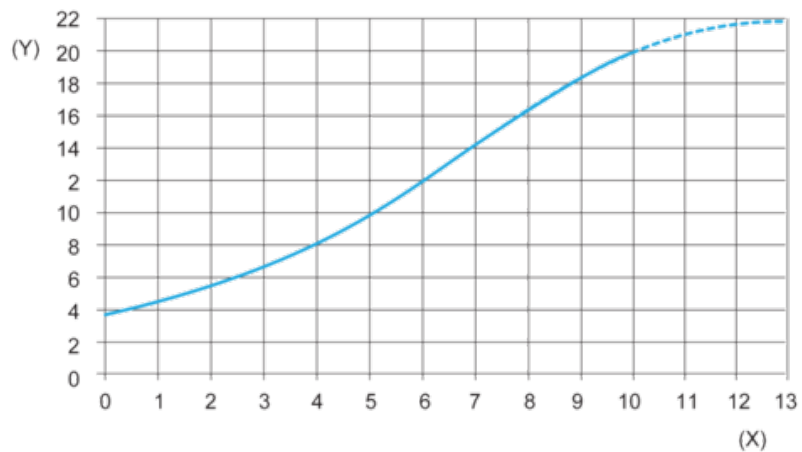

(Y) Is (mA)

(X) Sensors - object distance (mm)