

# XMLR010G2P09

Electronic pressure sensors, Pressure sensors XM, XMLR 10 bar, SAE 7/16 20UNF 2 B, 24 VDC, 2xPNP, M12



## Main

Range of product	Telemecanique Pressure sensors XM
Product or component type	Electronic pressure sensors
Pressure sensor type	Pressure transmitter
Pressure switch type of operation	Pressure switch with 2 switching outputs
Device short name	XMLR
Pressure rating	999.7 KPa 10 bar
Maximum permissible accidental pressure	40 Bar 4 MPa 3999.0 kPa
Destruction pressure	3999.0 KPa 40 Bar 4 MPa
Controlled fluid	Fresh water (0...80 °C) Air (-20...80 °C) Hydraulic oil (-20...80 °C) Refrigeration fluid (-20...80 °C)
Fluid connection type	SAE 7/16-20UNF-2B (female)
[Us] rated supply voltage	24 V DC SELV (voltage limits: 17...33 V)

## Complementary

Current consumption	<= 50 mA
Electrical connection	Male connector M12, 4 pins
Type of output signal	Discrete
Discrete output type	Solid state PNP, 2 NO/NC programmable
Maximum switching current	250 mA
Contacts type and composition	2 NO/NC programmable
Scale type	Fixed differential
Maximum voltage drop	2 V
Adjustable range of switching point on rising pressure	0.08...1 MPa 0.8...10 Bar 80.0...999.7 kPa
Adjustable range of switching point on falling pressure	0.5...9.7 Bar 49.99...972.2 KPa 0.05...0.97 MPa
Minimum differential travel	29.99 KPa 30 KPa 0.3 bar
Materials in contact with fluid	Fluorocarbon FKM (Viton) Ceramic 316L stainless steel
Front material	Polyester
Housing material	Polyacrylamide 316L stainless steel
Operating position	Any position, but disposals can falsified the measurement in case of upside down mounting
Protection type	Overvoltage protection Short-circuit protection Reverse polarity Overload protection

The information provided in this documentation contains general descriptions and/or technical characteristics of the performance of the products contained herein. This documentation is not intended as a substitute for and is not to be used for determining suitability or reliability of these products for specific user applications. It is the duty of any such user or integrator to perform the appropriate and complete risk analysis, evaluation and testing of the products with respect to the relevant specific application or use thereof. Neither TWSS Holding nor any of its affiliates or subsidiaries shall be responsible or liable for misuse of the information contained herein.

Response time on output	<= 5 ms for discrete output
Switching output time delay	0...50 s in steps of 1 second
Display type	4 digits 7 segments
Local signalling	2 LEDs (yellow) for light ON when switch is actuated
Display response time type	Fast 50 ms Normal 200 ms Slow 600 ms
Maximum delay first up	300 ms
Overall accuracy	<= 1 % of the measuring range
Measurement accuracy on switching output	<= 0.6 % of the measuring range
Repeat accuracy	<= 0.2 % of the measuring range
Drift of the sensitivity	+/- 0.03 % of measuring range/°C
Drift of the zero point	+/- 0.1 % of measuring range/°C
Display accuracy	<= 1 % of the measuring range
Mechanical durability	10000000 cycles
Depth	42 mm
Height	100 mm
Width	41 mm
Net weight	0.21 kg
[Uimp] rated impulse withstand voltage	0.5 kV DC
Electromagnetic compatibility	Susceptibility to electromagnetic fields: 10 V/m 80...2000 MHz conforming to IEC 61000-4-3 Immunity to conducted RF disturbances: 10 V 0.15...80 MHz conforming to IEC 61000-4-6 Surge immunity test: 1 kV conforming to IEC 61000-4-5 Electrical fast transient/burst immunity test: 2 kV conforming to IEC 61000-4-4 Electrostatic discharge immunity test: 8 kV air, 4 kV contact conforming to IEC 61000-4-2

## Environment

Marking	CE
Product certifications	cULus
Standards	IEC 61326-2-3 UL 61010-1
Ambient air temperature for operation	-20...80 °C
Ambient air temperature for storage	-40...80 °C
IP degree of protection	IP65 conforming to IEC 60529 IP67 conforming to IEC 60529
Vibration resistance	20 gn (f= 10...2000 Hz) conforming to IEC 60068-2-6
Shock resistance	50 gn conforming to IEC 60068-2-27

## Packing Units

Unit Type of Package 1	PCE
Number of Units in Package 1	1
Package 1 Height	6.5 cm
Package 1 Width	7.5 cm
Package 1 Length	12.7 cm
Package 1 Weight	181.0 g

## Offer Sustainability

California proposition 65	WARNING: This product can expose you to chemicals including: Diisononyl phthalate (DINP), which is known to the State of California to cause cancer, and Di-isodecyl phthalate (DIDP), which is known to the State of California to cause birth defects or other reproductive harm. For more information go to <a href="http://www.P65Warnings.ca.gov">www.P65Warnings.ca.gov</a>
For all Reach Rohs enquiries contact us at	<a href="mailto:sustainability@tesensors.com">sustainability@tesensors.com</a>

Dimensions

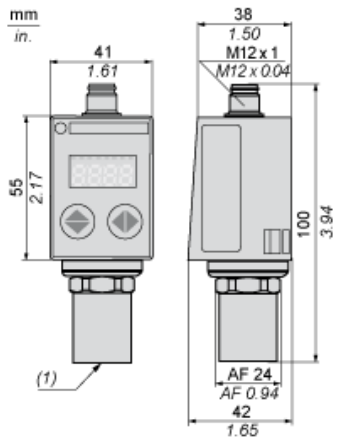

(1) Fluid entry: SAE 7/16-20UNF female

---

## Connections and Schema

---

### Connector Wiring

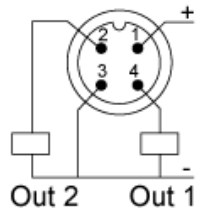

### Switching Output Description. Hysteresis Mode

The hysteresis switching mode is typically used for the “pumping and/or emptying applications”.

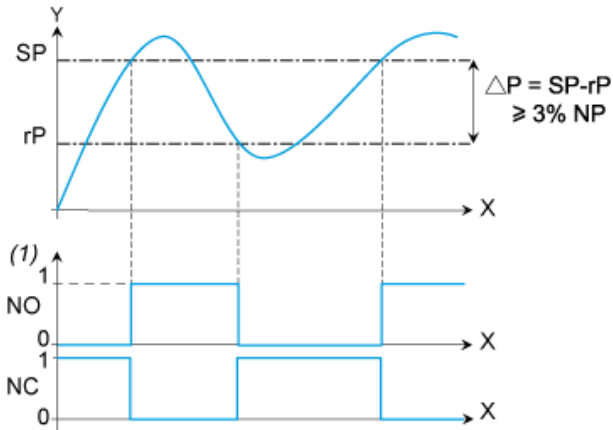

X : Time  
Y : Pressure  
(1) Output  
NP : Nominal Pressure  
SP : Set point (adjustable from 8 % to 100 % NP)  
rP : Reset point (adjustable from 5 % to 97 % NP)

### Switching Output Description. Window Mode

The window switching mode is typically used for the “pressure regulation applications”

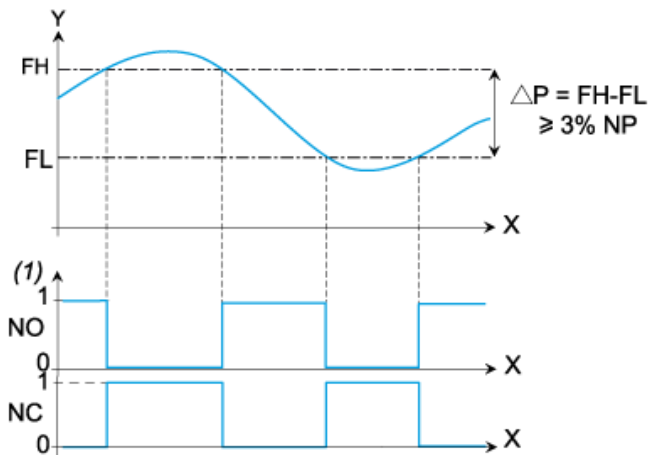

X : Time  
Y : Pressure  
(1) Output  
NP : Nominal pressure  
FH : High switching point (adjustable from 8 % to 100 % NP)  
FL : Low switching point (adjustable from 5 % to 97 % NP)

### Switching Output Description. Time Delay

The Time Delay is typically used to filter out the fast pressure transients.  
The output only switches after a time “dS” and “dr” adjustable from 0 to 50 seconds.

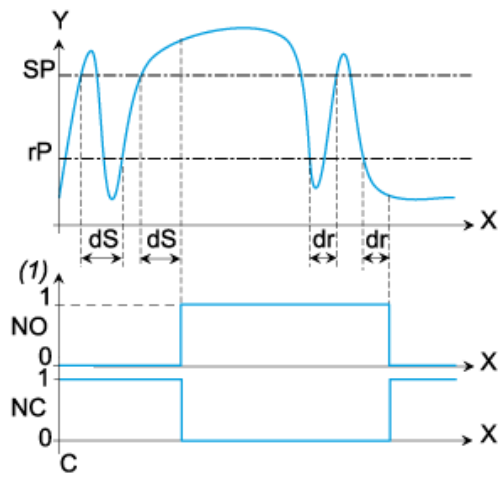

X : Time  
 Y : Pressure  
 (1) Output  
 SP : Set point  
 rP : Reset point  
 dS : Time delay on the set point  
 dr : Time delay on the reset point